



ÖZCIHAN MAKİNA
Özcihan Makina San. ve Tic. Ltd. Şti
www.ozcihan.com.tr



BALATALI REDÜKTÖR/CLUTCH REDUCER



ARAÇ MARKASI / TRUCK BRAND

TÜM ARAÇLAR İÇİN
FOR ALL TRUCKS

PTO KODU

CTM 264

TEKNİK ÇİZİM / TECHNICAL DRAWING

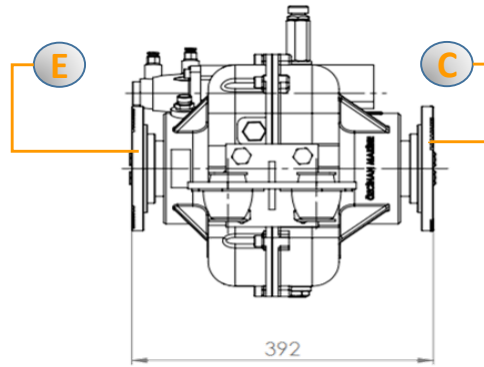
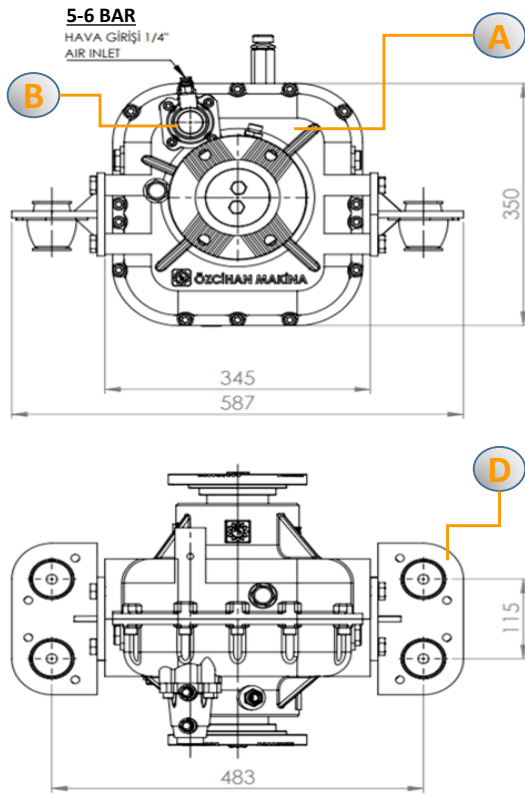

ÖZELLİKLER VE OPSİYONLAR / PROPERTYS & OPTIONS

A

PLANET SİSTEMİ / PLANET SYSTEM

B

HAVALI KONTROL / AIR CONTROL

C

GİRİŞ (İSTEĞE BAĞLI) / INPUT (OPTION)

D

YAN BAĞLANTI KİTİ / SIDE CONNECTION

E

ÇIKIŞ / OUTPUT

ÖMERLİ MH. SEÇİYE SK. NO:19 ARNAVUTKÖY/İSTANBUL
TEL:+90 212 798 3151 FAKS:+90 212 798 3152
E-MAIL: ozcihan@ozcihan.com.tr www.ozcihan.com.tr





ÖZCIHAN MAKİNA
Özcihan Makina San. ve Tic. Ltd. Şti
www.ozcihan.com.tr



REDÜKTÖRLÜ PTO / PTO REDUCER

C E

**GİRİŞ / INPUT
ÇIKIŞ / OUTPUT**

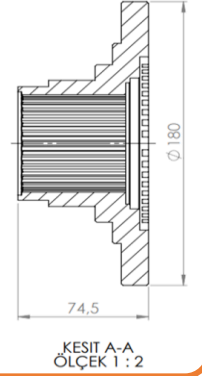
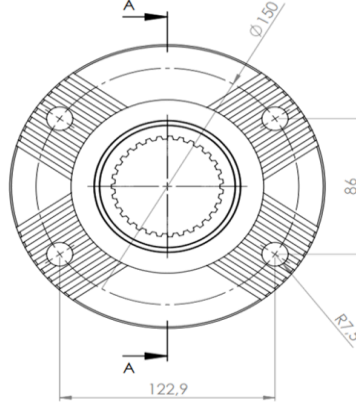

KESİT A-A
ÖLÇEK 1 : 2

1.12.264 Z:31 (ISO 8667)

TEKNİK BİLGİLENDİRME / TECHNICAL INFORMATION

C E

TORK / TORQUE: 260 HP

TAHVİL ORANI: 1/3,5

**DIŞLI TİPİ
GEAR TYPE**

DÜZ



**DÖNÜŞ YÖNÜ
ROTATION SENSE**

GİRİŞ



**AĞIRLIK / WEIGHT
67 KG**

BAĞLANTI / MOUNTING SIDE

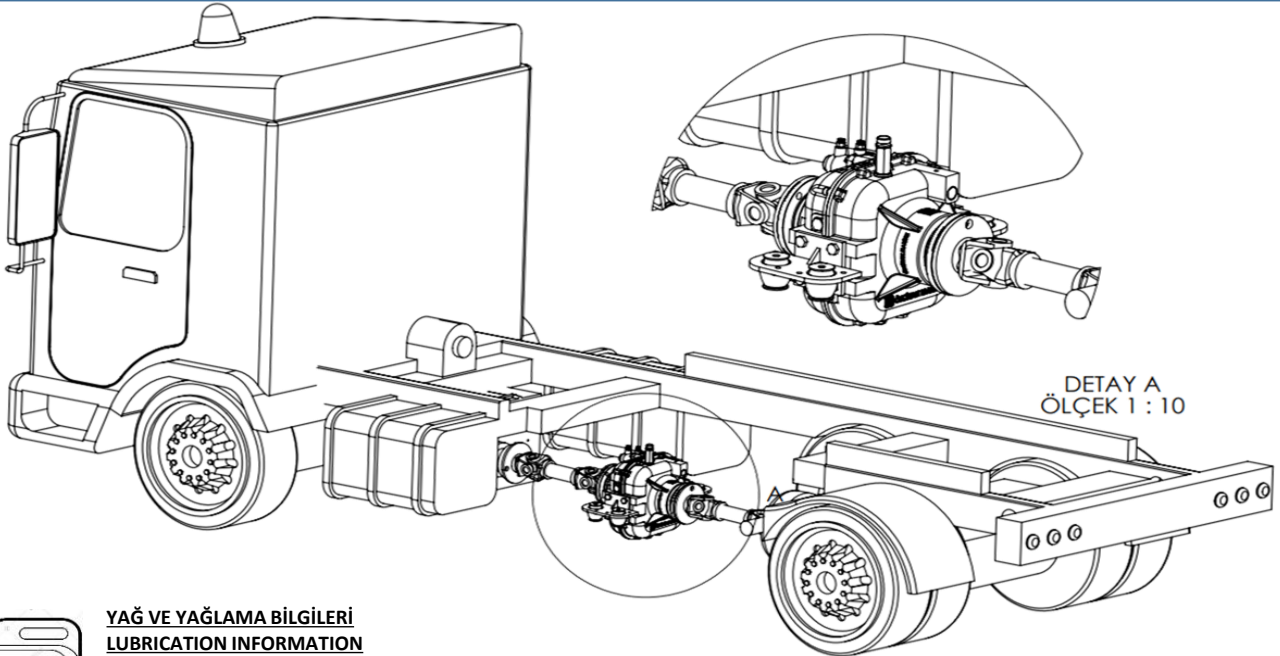

DETAY A
ÖLÇEK 1 : 10



YAĞ VE YAĞLAMA BİLGİLERİ

LUBRICATION INFORMATION

3,5 LT SAE 80W 90 EP-SHC 626

DEĞİŞİM SÜRE: İLK YAĞ DEĞİŞİMİ:110 SAAT

SONRAKİ YAĞ DEĞİŞİMİ:550 SAAT veya 1 YIL

REPLACE TIME:FIRST OIL CHANGE:110 HOURS

NEXT OIL CHANGES:550 HOURS OR 1 YEAR

**. BU BAĞLANTI ŞEMASI TÜM PLANET REDÜKTÖR SİSTEMLERİ İÇİN GEÇERLİDİR.
. THIS INSTALLATION ILLUSTRATION CAN BE APPLIED TO ALL PLANET REDUCER SYSTEMS.**

ÖMERLİ MH. SECİYESK. NO:19 ARNAVUTKÖY/İSTANBUL
TEL:+90 212 798 3151 FAKS:+90 212 798 3152
E-MAIL: ozcihan@ozcihan.com.tr www.ozcihan.com.tr

